

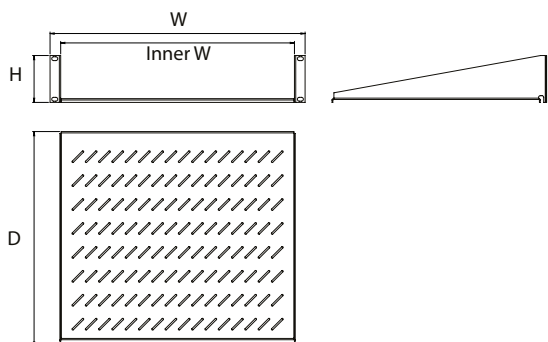

# ACCESSORIES

# 19" CANTILEVER SHELF



<b>Material</b>	1.5 mm Steel
<b>Color</b>	RAL 7035 and RAL 9005
<b>Maximum Static Load</b>	15-25 kg
<b>Finish</b>	Electrostatic Powder Paint
<b>Packaging</b>	One piece in a box

H (U)	D (mm)	W (mm)	Inner W (mm)	Weight (kg)	Part No
1U	150	483	437	0,8	CCA-X-1001
1U	250	483	437	1,1	CCA-X-1001-01
1U	300	483	437	1,6	CCA-X-1001-04
1U	450	483	437	2,9	CCA-X-1001-02
1U	600	483	437	4,4	CCA-X-1001-03
2U	250	483	437	1,4	CCA-X-1002
2U	300	483	437	1,5	CCA-X-1002-02
2U	350	483	437	1,6	CCA-X-1002-01
2U	400	483	437	2,4	CCA-X-1003

# 19" FIXED SHELF



<b>Material</b>	1 mm Steel
<b>Color</b>	RAL 7035 and RAL 9005
<b>Maximum Static Load</b>	50 kg
<b>Finish</b>	Electrostatic Powder Paint
<b>Packaging</b>	One piece in a box

H (U)	D (mm)	W (mm)	Weight (kg)	Part No
1U	345	482	1,2	CCA-X-1004
1U	400	482	1,4	CCA-X-1004-01
1U	525	482	1,8	CCA-X-1005
1U	700	482	2,4	CCA-X-1006

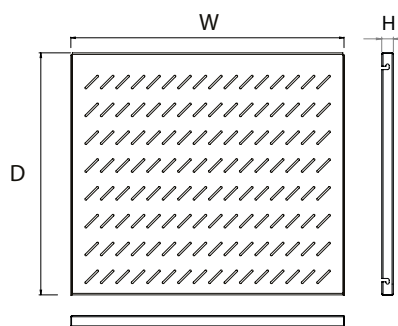

X (Color code): 7:RAL 7035 Light Grey, 9:RAL 9005 Black

# 19" HEAVY DUTY FIXED SHELF

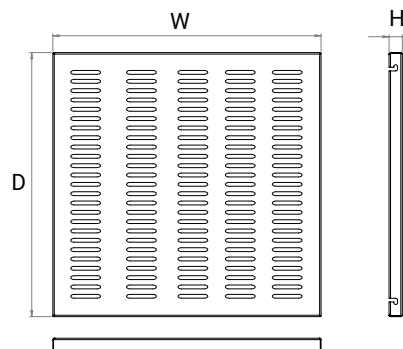

<b>Material</b>	1.5 mm Steel
<b>Color</b>	RAL 7035 and RAL 9005
<b>Maximum Static Load</b>	100 kg
<b>Finish</b>	Electrostatic Powder Paint
<b>Packaging</b>	One piece in a box

H (U)	D (mm)	W (mm)	Inner W (mm)	Weight (kg)	Part No
1U	400	483	435	2,95	CCA-X-1008
1U	600	483	435	3,95	CCA-X-1009
1U	800	483	435	4,95	CCA-X-1010

# 19" SLIDING SHELF

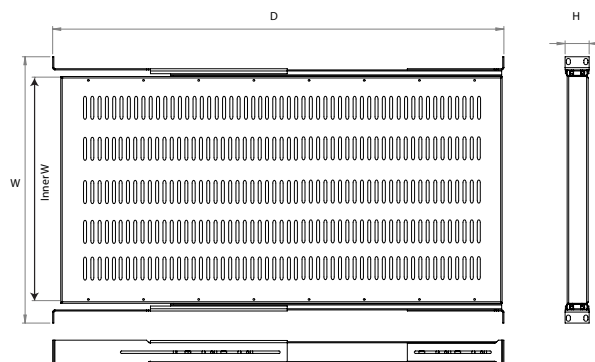

<b>Material</b>	1.5 mm Steel
<b>Color</b>	RAL 7035 and RAL 9005
<b>Maximum Static Load</b>	35 kg
<b>Finish</b>	Electrostatic Powder Paint
<b>Packaging</b>	One piece in a box

H (U)	D (mm)	W (mm)	Inner W (mm)	Weight (kg)	Part No
1U	400	483	411	2,37	CCA-X-1012
1U	600	483	411	3,56	CCA-X-1013
1U	800	483	411	4,74	CCA-X-1014

# 19" DRAWER

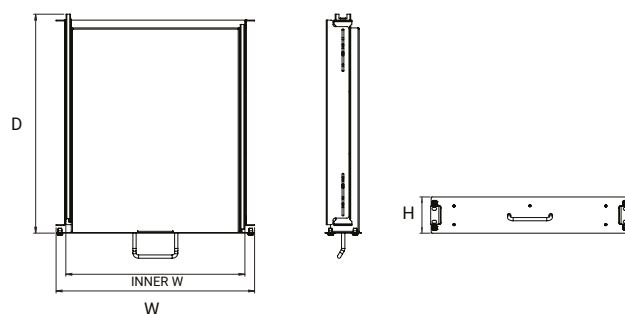

<b>Material</b>	1.5 mm Steel
<b>Color</b>	RAL 7035 and RAL 9005
<b>Maximum Static Load</b>	35 kg
<b>Finish</b>	Electrostatic Powder Paint
<b>Packaging</b>	One piece in a box

H (U)	D (mm)	W (mm)	Inner W (mm)	Weight (kg)	Part No
2U	500	483	435	6,36	CCA-X-1016
3U	500	483	435	9,54	CCA-X-1017

X (Color code): 7:RAL 7035 Light Grey, 9:RAL 9005 Black

# 19" 1U FAN MODULE

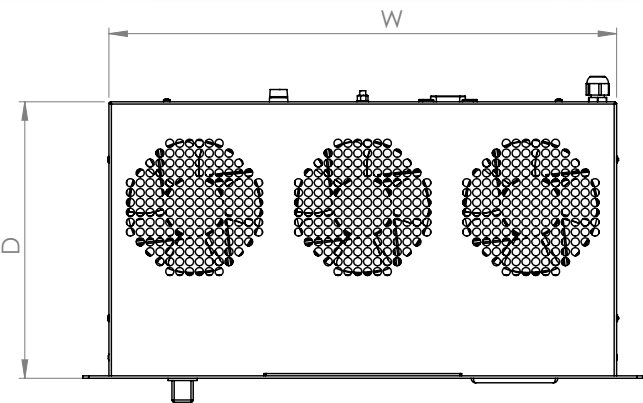

<b>Operating Voltage</b>	AC 220 / 240 Volts 50/60 Hz
<b>Standards</b>	Conforms to IEC 297-1
<b>Air Flow</b>	85 / 90 CFM
<b>Noise</b>	42 / 49 dB (A)
<b>Fan Speed</b>	2600 / 2900 rpm
<b>Material</b>	1,5 mm Steel
<b>Color</b>	RAL 7035 and RAL 9005
<b>Finish</b>	Electrostatic Powder Paint
<b>Packaging</b>	One piece in a box

H (U)	D (mm)	W (mm)	Number of Fans	Weight (kg)	Part No
1U	258	483	3	4,19	CCA-X-2001

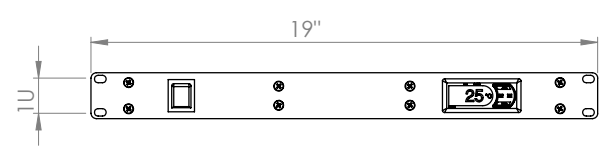

# FAN MODULE FOR WALL MOUNT ENCLOSURES

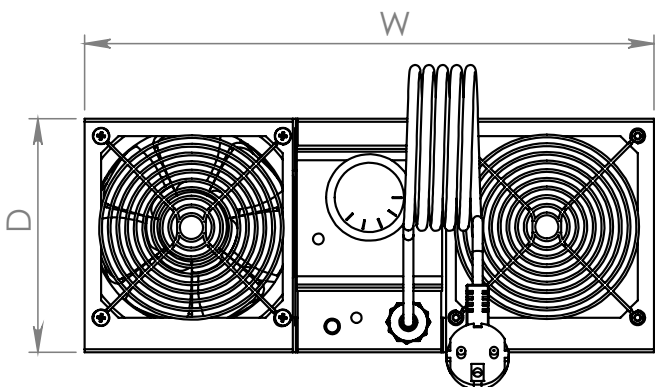

<b>Operating Voltage</b>	AC 220 / 240 Volts 50/60 Hz
<b>Standards</b>	Conforms to IEC 297-1
<b>Air Flow</b>	85 / 90 CFM
<b>Noise</b>	42 / 49 dB (A)
<b>Fan Speed</b>	2600 / 2900 rpm
<b>Material</b>	1,5 mm Steel
<b>Color</b>	RAL 7035 and RAL 9005
<b>Finish</b>	Electrostatic Powder Paint
<b>Packaging</b>	One piece in a box

H (mm)	D (mm)	W (mm)	Number of Fans	Weight (kg)	Part No
39	135	326	1	1,27	CWA-X-2001
39	135	326	2	1,80	CWA-X-2002

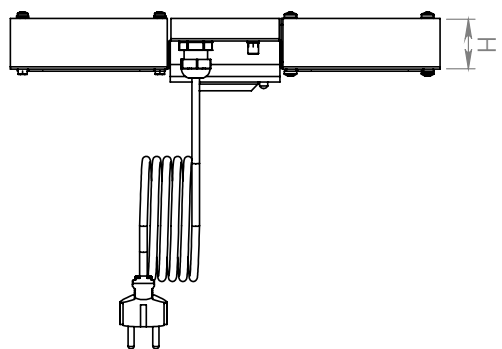

X (Color code): 7:RAL 7035 Light Grey, 9:RAL 9005 Black

## FAN MODULE FOR INORAX-AL SERIES

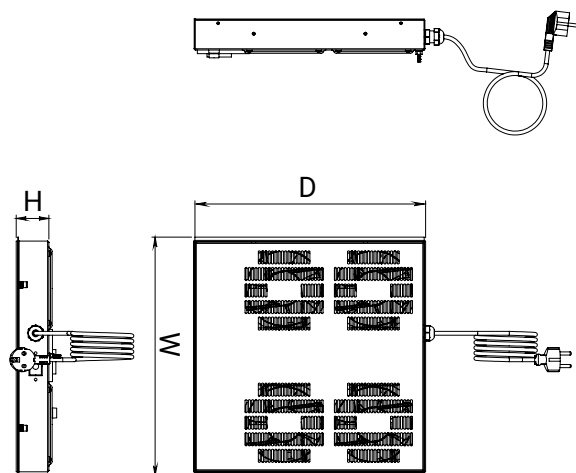

<b>Operating Voltage</b>	AC 220 / 240 Volts 50/60 Hz
<b>Standards</b>	Conforms to IEC 297-1
<b>Air Flow</b>	85 / 90 CFM
<b>Noise</b>	42 / 49 dB (A)
<b>Fan Speed</b>	2600 / 2900 rpm
<b>Material</b>	1,5 mm Steel
<b>Color</b>	RAL 7035 and RAL 9005
<b>Finish</b>	Electrostatic Powder Paint
<b>Packaging</b>	One piece in a box

H (mm)	D (mm)	W (mm)	Number of Fans	Weight (kg)	Part No
49	373	411	2	3,76	CPA-X-2001
49	373	411	4	4,81	CPA-X-2002
49	373	411	6	6,74	CPA-X-2003

- 2-4 Fan trays can only be used in 600-800 mm depth cabinets, not for 1000 mm and bigger depth cabinets.
- 6 Fan tray can only be used in 1000 mm and bigger depth cabinets, not for 600-800 mm depth cabinets

## FAN MODULE FOR INORAX-ST SERIES

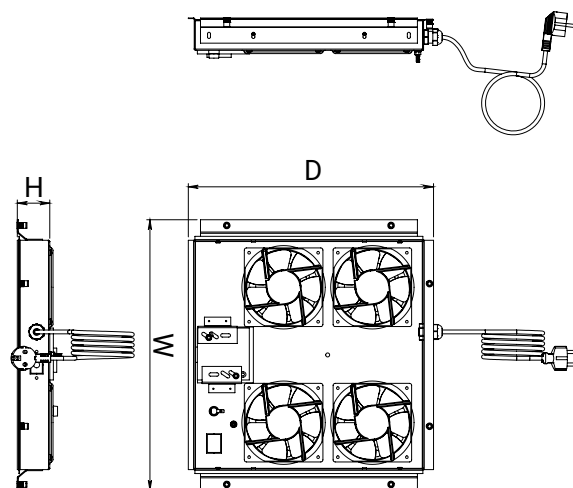

<b>Operating Voltage</b>	AC 220 / 240 Volts 50/60 Hz
<b>Standards</b>	Conforms to IEC 297-1
<b>Air Flow</b>	85 / 90 CFM
<b>Noise</b>	42 / 49 dB (A)
<b>Fan Speed</b>	2600 / 2900 rpm
<b>Material</b>	1,5 mm Steel
<b>Color</b>	RAL 7035 and RAL 9005
<b>Finish</b>	Electrostatic Powder Paint
<b>Packaging</b>	One piece in a box

H (mm)	D (mm)	W (mm)	Number of Fans	Weight (kg)	Part No
49	373	411	2	2,90	CSA-X-2001
49	373	411	4	3,95	CSA-X-2002

X (Color code): 7:RAL 7035 Light Grey, 9:RAL 9005 Black

# FAN MODULE FOR WALL MOUNT ENCLOSURES

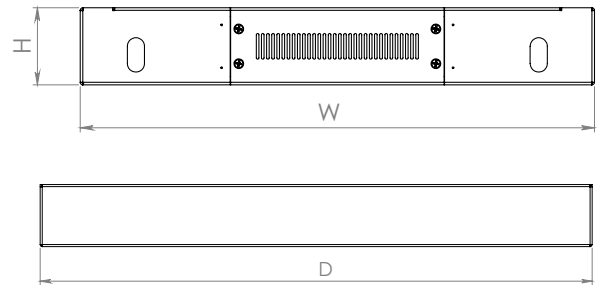

<b>Material</b>	1,5 mm Steel
<b>Color</b>	RAL 7035 and RAL 9005
<b>Finish</b>	Electrostatic Powder Paint
<b>Packaging</b>	One piece in a box

H (mm)	W (mm)	D (mm)	Weight (kg)	Part No
90	600	600	5,95	CCA-X-3001
90	600	800	7,1	CCA-X-3002
90	600	1000	7,96	CCA-X-3003
90	600	1100	8,83	CCA-X-3004
90	600	1200	9,71	CCA-X-3005
90	800	800	7,27	CCA-X-3006
90	800	1000	8,14	CCA-X-3007
90	800	1100	9,01	CCA-X-3008
90	800	1200	9,89	CCA-X-3009

# SLIDING ANTI-SWING STABILIZER



<b>Material</b>	1,5 mm Steel
<b>Color</b>	RAL 7035 and RAL 9005
<b>Finish</b>	Electrostatic Powder Paint
<b>Packaging</b>	One piece in a box

H (mm)	W (mm)	D (mm)	Weight (kg)	Part No
90	600	1000	9	CPA-X-3019
90	600	1070	10	CPA-X-3026
90	600	1200	12	CPA-X-3021
90	800	800	12	CPA-X-3022
90	800	1000	13	CPA-X-3023
90	800	1070	14	CPA-X-3027
90	800	1200	15	CPA-X-3025

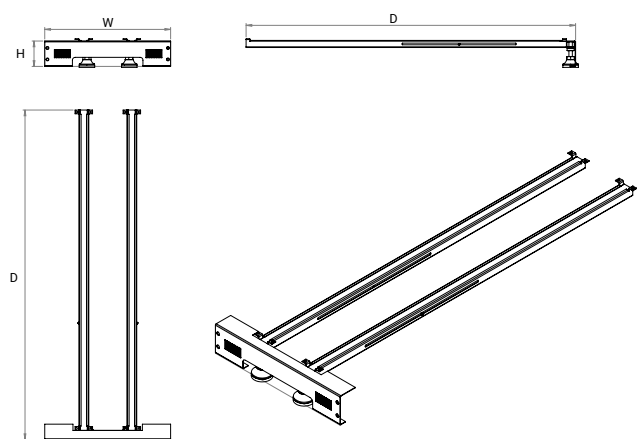

X (Color code): 7:RAL 7035 Light Grey, 9:RAL 9005 Black

## 19" 1 & 2U PLASTIC BLANKING PANEL TYPE 1

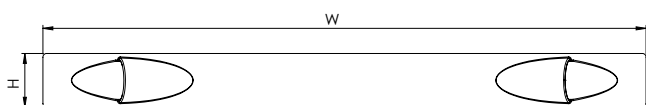

Material	Plastic ABS
Color	RAL 7035 and RAL 9005
Packaging	One piece in a box

H (U)	D (mm)	W (mm)	Weight (kg)	Part No
1U	22	483	0,11	CCA-X-4015
2U	22	483	0,214	CCA-X-4016

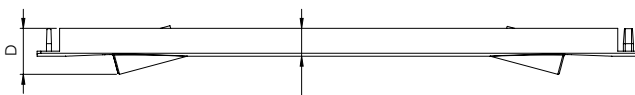

## 19" 1U PLASTIC BLANKING PANEL TYPE 2

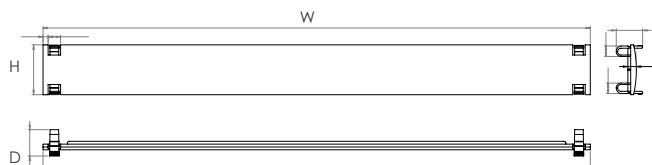

Material	Plastic ABS
Color	RAL 7035 and RAL 9005
Packaging	One piece in a box

H (U)	D (mm)	W (mm)	Weight (kg)	Part No
1U	8,5	485	0,08	CCA-X-4001

## 19" STEEL BLANKING PANELS

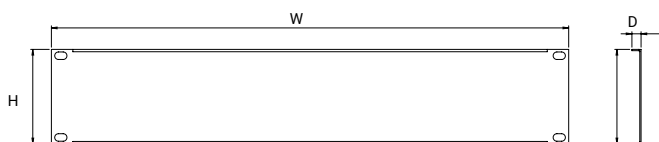

Material	1 mm Steel
Color	RAL 7035 and RAL 9005
Finish	Electrostatic Powder Paint
Packaging	One piece in a box

H (U)	D (mm)	W (mm)	Weight (kg)	Part No
1U	9	483	0,26	CCA-X-4002
2U	9	483	0,46	CCA-X-4003
4U	9	483	0,86	CCA-X-4004

## 19" VENTILATED BLANKING PANELS

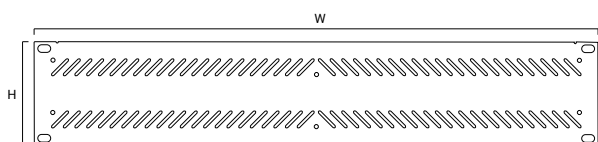

Material	1 mm Steel
Color	RAL 7035 and RAL 9005
Finish	Electrostatic Powder Paint
Packaging	One piece in a box

H (U)	D (mm)	W (mm)	Weight (kg)	Part No
1U	9	483	0,24	CCA-X-4005
2U	9	483	0,42	CCA-X-4006

X (Color code): 7:RAL 7035 Light Grey, 9:RAL 9005 Black

## 19" 1U HORIZONTAL CABLE ORGANIZER WITH PLASTIC HOOKS

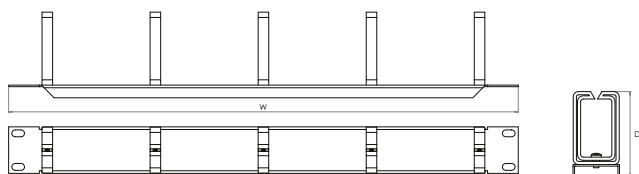

Material	1,2 mm Steel
Color	RAL 7035 and RAL 9005
Finish	Electrostatic Powder Paint
Packaging	One piece in a box

H (U)	D (mm)	W (mm)	Weight (kg)	Part No
1U	80	483	0,49	CCA-X-5001

## 19" 1 & 2 U HORIZONTAL CABLE ORGANIZER WITH METAL HOOKS

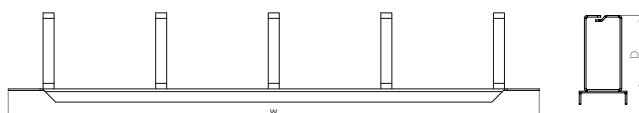

Material	1,2 mm Steel
Color	RAL 7035 and RAL 9005
Finish	Electrostatic Powder Paint
Packaging	One piece in a box

H (U)	D (mm)	W (mm)	Weight (kg)	Part No
1U	80	483	0,50	CCA-X-5044
2U	80	483	0,65	CCA-X-5055

## 19" COVERED CABLE ORGANIZER

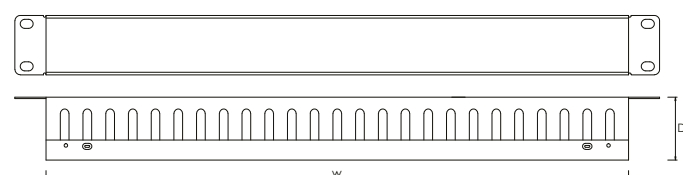

Material	1 mm Steel
Color	RAL 7035 and RAL 9005
Finish	Electrostatic Powder Paint
Packaging	One piece in a box

H (U)	D (mm)	W (mm)	Weight (kg)	Part No
1U	47	482,4	0,6	CCA-X-5004

X (Color code): 7:RAL 7035 Light Grey, 9:RAL 9005 Black

## 19" HINGED COVERED CABLE ORGANIZER



Material	Plastic ABS
Color	RAL 7035 and RAL 9005
Packaging	One piece in a box

H (U)	D (mm)	W (mm)	Weight (kg)	Part No
1U	80	485	0,25	CCA-X-5050
2U	110	485	0,63	CCA-X-5051

## 19" CABLE ENTRY PANEL

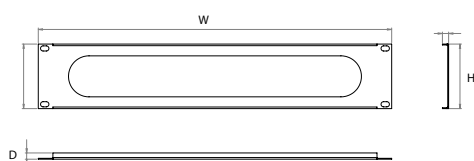

Material	1 mm Steel
Color	RAL 7035 and RAL 9005
Finish	Electrostatic Powder Paint
Packaging	One piece in a box

H (U)	D (mm)	W (mm)	Weight (kg)	Part No
1U	9	483	0,2	CCA-X-5029
2U	9	483	0,3	CCA-X-5030

## CABLE HOOK

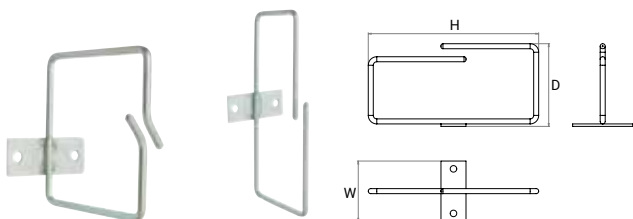

Material	Steel
Finish	Zinc Plated
Packaging	One piece in a Nylon

H (mm)	D (mm)	W (mm)	Weight (kg)	Part No
100	100	60	0,09	CCA-0-5002
170	80	60	0,10	CCA-X-5003

## 19" CABLE ENTRY PANEL WITH BRUSH

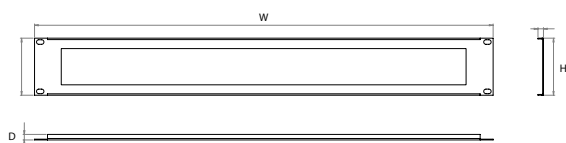

Material	1,2 mm Steel, Brush
Finish	Electrostatic Powder Paint
Packaging	One piece in a box

H (U)	D (mm)	W (mm)	Weight (kg)	Part No
1U	10	483	0,2	CCA-X-5031
2U	10	483	0,3	CCA-X-5032

## VERTICAL SIDE CABLE ORGANIZER TYPE 1

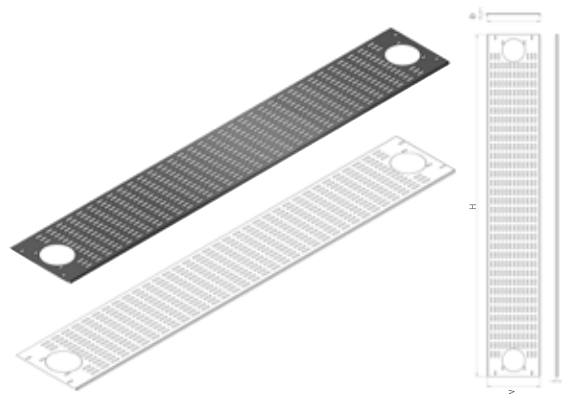

Material	1,5 mm Steel
Finish	Zinc Plated
Packaging	Two pieces in Bubble Nylon

H (U)	H (mm)	D (mm)	W (mm)	Weight (kg)	Part No
26U	1246	8	260	6,4	CCA-0-5011
32U	1510	8	260	7,8	CCA-0-5012
36U	1686	8	260	8,72	CCA-0-5013
39U	1820	8	260	9,48	CCA-0-5014
42U	1950	8	260	10,22	CCA-0-5015
47U	2170	8	260	11,6	CCA-0-5016

X (Color code): 7:RAL 7035 Light Grey, 9:RAL 9005 Black

## VERTICAL SIDE CABLE ORGANIZER TYPE 2

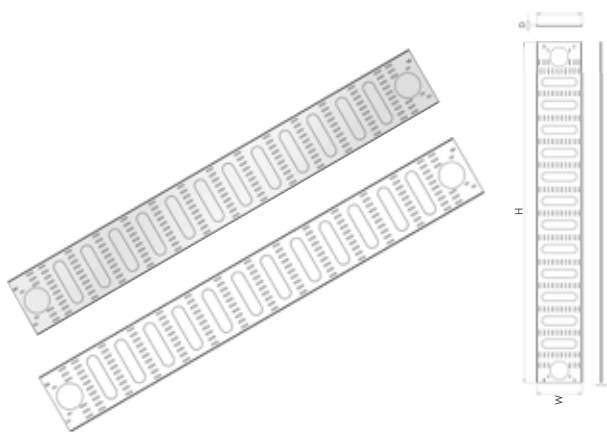

<b>Material</b>	1,5 mm Steel
<b>Color</b>	RAL 7035 and RAL 9005
<b>Finish</b>	Electrostatic Powder Paint
<b>Packaging</b>	Two pieces in a box

H (U)	H (mm)	D (mm)	W (mm)	Weight (kg)	Part No
26U	1246	8	260	6,0	CCA-X-5017
32U	1510	8	260	7,2	CCA-X-5018
36U	1686	8	260	8,0	CCA-X-5019
39U	1820	8	260	8,9	CCA-X-5020
42U	1950	8	260	9,0	CCA-X-5021
47U	2170	8	260	10,8	CCA-X-5022

## MODULAR ADJUSTABLE VERTICAL CABLE ORGANIZER TYPE 1

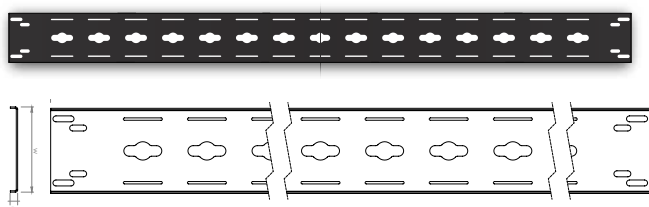

<b>Material</b>	1,5 mm Steel
<b>Color</b>	RAL 7035 and RAL 9005
<b>Finish</b>	Electrostatic Powder Paint
<b>Packaging</b>	One piece in a box
<b>Module Capacity</b>	42U (max. 26 pcs) 47U (max. 29 pcs) * Cable management hooks

H (U)	D (mm)	W (mm)	Weight (kg)	Part No
42U	13	90	2,83	CCA-X-5023
47U	13	90	3,17	CCA-X-5024

## CABLE MANAGEMENT HOOKS



<b>Material</b>	1,5 mm Steel
<b>Color</b>	RAL 7035 and RAL 9005
<b>Finish</b>	Electrostatic Powder Paint
<b>Packaging</b>	One piece in a box
<b>Module Capacity</b>	42U (max. 26 pcs) 47U (max. 29 pcs)

H (mm)	D (mm)	W (mm)	Weight (kg)	Part No
50	70	84	0,42	CCA-X-5025

## FRONT & REAR ORGANIZER

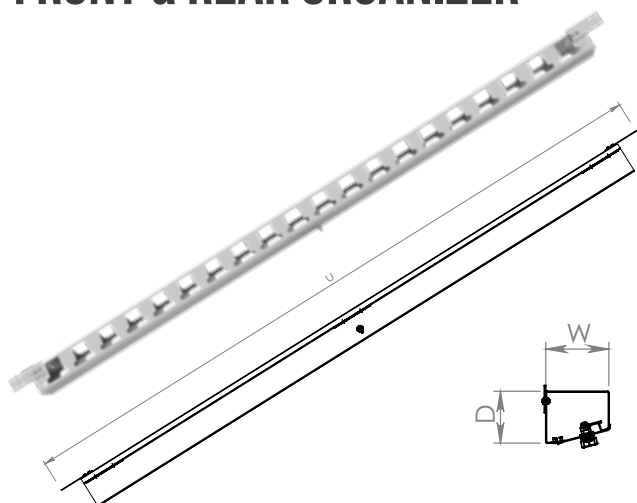

<b>Material</b>	1 mm Steel
<b>Color</b>	RAL 7035 and RAL 9005
<b>Finish</b>	Electrostatic Powder Paint
<b>Packaging</b>	Two pieces in a box

H (mm)	D (mm)	W (mm)	Weight (kg)	Part No
26U	92	100	7,6	CCA-X-5005
32U	92	100	8,2	CCA-X-5006
36U	92	100	9,4	CCA-X-5007
39U	92	100	10,2	CCA-X-5008
42U	92	100	11	CCA-X-5009
47U	92	100	12,4	CCA-X-5010

\*\*Only for 800mm width cabinets

X (Color code): 7:RAL 7035 Light Grey, 9:RAL 9005 Black

# FINGER DUCT VERTICAL CABLE MANAGER

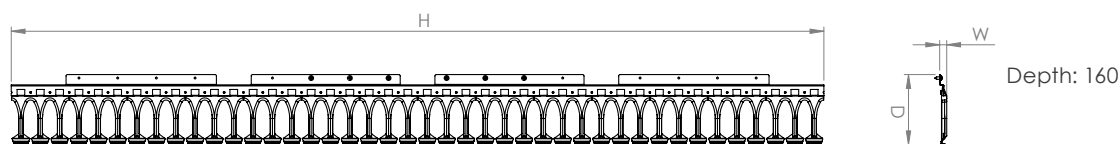
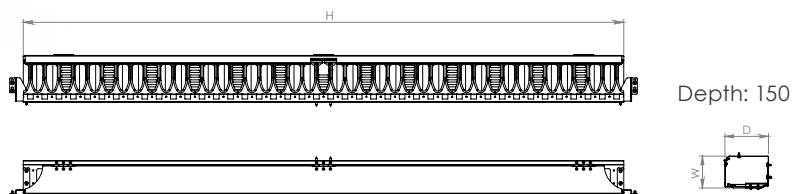

<b>Material</b>	ABS, Steel
<b>Color</b>	RAL 7035 and RAL 9005
<b>Finish</b>	Electrostatic Powder Paint
<b>Packaging</b>	Two pieces in a box

H (U)	H (mm)	D (mm)	W (mm)	Weight (kg)	Part No
22U	981	150	110	7	CCA-X-5026-22U
27U	1204	150	110	9	CCA-X-5026-27U
32U	1425	150	110	10	CCA-X-5026-32U
36U	1600	150	110	12	CCA-X-5026-36U
42U	1870	150	110	13	CCA-X-5026
47U	2095	150	110	14	CCA-X-5027
Only for 800mm width cabinets					

H (U)	H (mm)	D (mm)	W (mm)	Weight (kg)	Part No
42U	1867	160	20	4	CCA-X-5066
47U	2090	160	20	5	CCA-X-5067
Only for 600mm width cabinets					

X (Color code): 7:RAL 7035 Light Grey, 9:RAL 9005 Black

## 19" 1U LED LIGHT

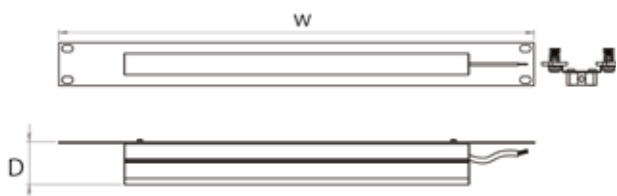

Material	1,2 mm Steel
Finish	Electrostatic Powder Paint
Packaging	One piece in a box
Power Consumption	11W
Voltage	AC 220 - 240 Volts 50/60 Hz

H (U)	D (mm)	W (mm)	Weight (kg)	Part No
1U	43	483	0,5	CCA-X-7001

## LED LIGHT

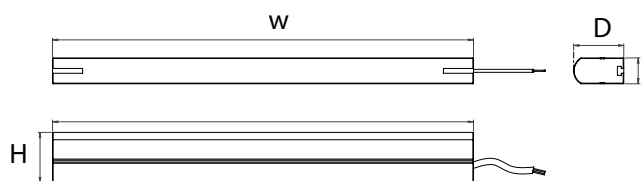

Material	Anodized Aluminium Extrusion
Packaging	One piece in a box
Power Consumption	11W
Voltage	AC 220 - 240 Volts 50/60 Hz

H (mm)	D (mm)	W (mm)	Weight (kg)	Part No
320	20	20	0,25	CCA-0-7025*
320	20	20	0,25	CCA-0-7026 **

\* without plug  
 \*\* with CEE 7/16 type C plug

## CABLE GUIDE BRUSH STRIP



Material	Plastic, Brush
Packaging	Two pieces 350 mm parts in a box

H1 (mm)	H2 (mm)	W (mm)	Weight (kg)	Part No
18	30	350	0,15	CCA-9-5046

## ADJUSTABLE CABLE ENTRY PANEL WITH BRUSH FOR INORAX-AL

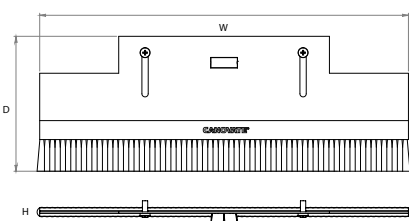

Material	Plastic, Brush
Color	RAL 7035 and RAL 9005
Packaging	One piece in a box

H (mm)	D (mm)	W (mm)	Weight (kg)	Part No
12,5	128	350	0,78	CPA-X-5047
12,5	128	168	0,37	CPA-X-5048

CPA-X-5048 for Bottom of Seismic Cabinet 600 mm width

X (Color code): 7:RAL 7035 Light Grey, 9:RAL 9005 Black

## CABLE CLAMP RAIL

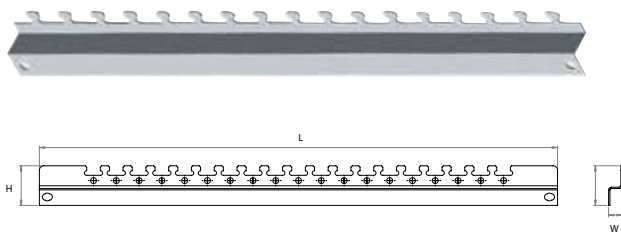

Material	1,5 mm Steel
Finish	Zinc Plated
Packaging	One piece in a box

Cabinet Depth (mm)	L (mm)	H (mm)	W (mm)	Weight (kg)	Part No
600	339	64	15	0,36	CCA-0-5033
800	539	64	15	0,48	CCA-0-5034
1000	739	64	15	0,60	CCA-0-5035
1200	939	64	15	0,72	CCA-0-5036

## C-RAIL

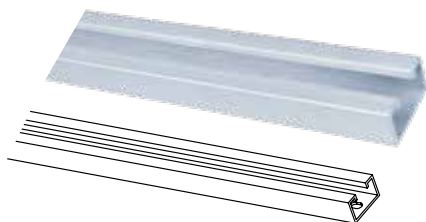

Material	Anodized Aluminium Profile
Finish	Anodization
Packaging	One piece in a box

Cabinet Depth (mm)	L (mm)	H (mm)	W (mm)	Weight (kg)	Part No
600	325	20	34	0,3	CCA-0-5037
800	525	20	34	0,39	CCA-0-5038
1000	725	20	34	0,49	CCA-0-5039
1200	925	20	34	0,59	CCA-0-5040

## CABLE CLAMP FOR C-RAIL



Material	Steel
Finish	Zinc Plated
Packaging	Five pieces in a box

Cabinet Diameter (mm)	Weight (kg)	H (mm)
8 - 12	0,042	CCA-0-5041
11 - 18	0,048	CCA-0-5042
12 - 23	0,054	CCA-0-5043

## CHASSIS RAIL

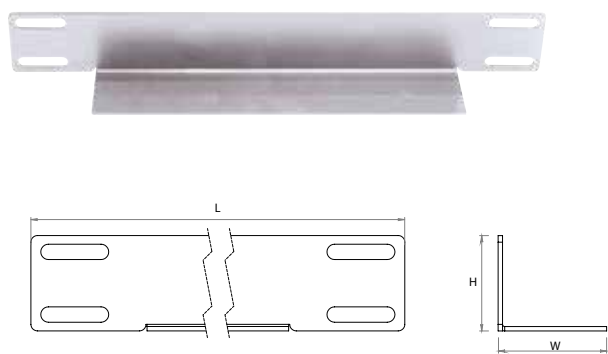

Material	2 mm Steel
Finish	Zinc Plated
Packaging	Two pieces in a box

Cabinet Depth (mm)	L (mm)	H (mm)	W (mm)	Weight (kg)	Part No
600	336	43,5	49,5	0,47	CCA-0-7002
800	536	43,5	49,5	0,63	CCA-0-7003
1000	736	43,5	49,5	0,79	CCA-0-7004
1200	936	43,5	49,5	0,95	CCA-0-7030

## EARTHING KIT



Material	Copper
Finish	PVC Jacket
Packaging	One set in a box

Length (mm)	Cross Section (mm <sup>2</sup> )	Weight (kg)	Part No
300	2,5	0,08	CCA-0-7017

# EARTHING BAR



<b>Material</b>	Copper
<b>Packaging</b>	One set in a box

Length (mm)	Thickness x Width (mm)	Weight (gr)	Part No
490	3x15	278	CCA-0-7019
140	3x15	76	CCA-0-7021

# BAYING KIT FOR INORAX-ST SERIES

<b>Material</b>	2 mm Galvanized Steel
<b>Packaging</b>	Four pieces in a set

H (mm)	D (mm)	W (mm)	Weight (kg)	Part No
23	86	52	0,125	CSA-0-7001

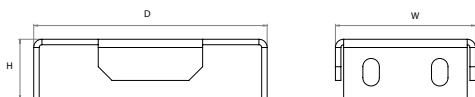

\* It can be used with the cabinet without side panels.

# BAYING KIT FOR INORAX-AL SERIES

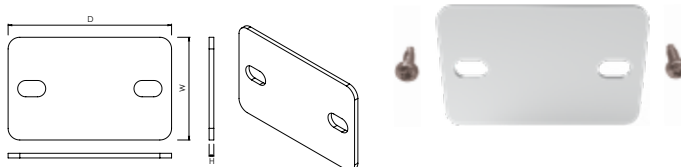

<b>Material</b>	2 mm Galvanized Steel
<b>Packaging</b>	Four pieces in a set

H (mm)	D (mm)	W (mm)	Weight (kg)	Part No
2	70	44	0,055	CPA-0-7001

\* It can be used with the cabinet without side panels.

# INORAX SERIES BAYING KIT

H (mm)	D (mm)	W (mm)	Weight (kg)	Part No	Which Product is Used?
1.2	65	41	0.125	DC-B5-X-YYYY0	Inorax-AL
20	80	45	0.24	DC-B5-X-YYYY0-CS	Inorax-ST
1.2	50	41	0.8	DC-B5-X-YYYY0-FS	Inorax-AL - INROW
20	58	55	0.16	DC-B5-X-YYYY0-CS-FS	Inorax-ST - INROW

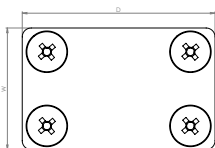

Inorax-AL

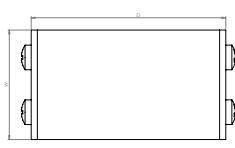

Inorax-ST

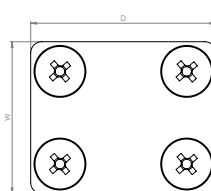

Inorax-AL - INROW

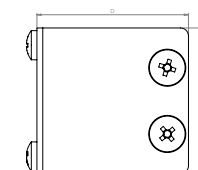

Inorax-ST - INROW

## CASTOR SET



<b>Material</b>	Steel and Plastic ABS
<b>Finish</b>	Zinc Plated
<b>Packaging</b>	Two pieces with stopper and two pieces without stopper in a box

Maximum Static Load	Diameter (mm)	Hole Diameter (mm)	Part No
150 kg / piece	0,77	12	CCA-0-7040

mm	mm	mm	mm	mm	kg	kg
55	25	M 12	30	84	0,4	150

## ADJUSTABLE FEET

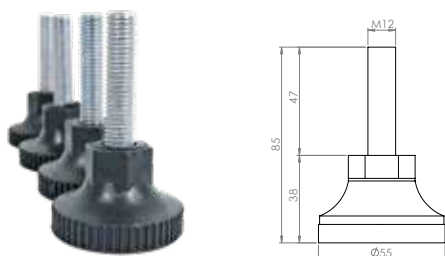

<b>Material</b>	Steel and Plastic ABS
<b>Finish</b>	Zinc Plated
<b>Packaging</b>	Four pieces with stopper in a box

Maximum Static Load	Set Weight (kg)	Part No
600 kg / piece	0,35	CCA-0-7014

## CAGE NUT & BOLT & PLASTIC CUP WASTER SET



<b>Material</b>	Steel
<b>Finish</b>	Zinc Plated
<b>Diameter</b>	6 mm (M6)
<b>One Set Includes</b>	20 pieces of M6x15 Screw, M6 Nut, M6 Polyamide Washer

Quantity in a set	Set Weight (kg)	Part No
20	0,10	CCA-0-7018

## KVM



### Technical Specifications

- 17"/19" TFT LCD Display
- 8/16 Port KVM Switch
- On Screen Display
- Hot Key Function
- Hot Plug Function

### Overview

Integral console controls computers and servers inside cabinets or server room with one LCD monitor, keyboard and mouse. This prevents unnecessary costs and saves space.

Sliding rail mount reduces occupied space inside cabinets. 8 or 16 computers can be connected. Daisy chain structure provides 3 level cascade connection and controllability up to 999 computers.

LCD Panel Size	Connection Type	8 Port	16 Port
17"	USB	CCA-O-8001	CCA-O-8005
17"	PS/2	CCA-O-8002	CCA-O-8006
19"	USB	CCA-O-8003	CCA-O-8007
19"	PS/2	CCA-O-8004	CCA-O-8008

## ADJUSTABLE RAISED FLOOR MODULE FOR SERVER & NETWORK CABINETS



Material	2 mm Steel
Finish	Electrostatic Powder Paint
Packaging	One piece in a set/Unasssembled
Maximum Static Load	2000 kg
Color	Ral 7035 or 9005

H (mm)	W (mm)	D (mm)	Weight (kg)	Part No
450-650	600	800-1200	25	CPA-X-7036
450-650	800	800-1200	30	CPA-X-7037

## STABILIZER FOR RASIED FLOOR



Material	4 mm Steel
Finish	Electrostatic Powder Paint
Packaging	Set includes 4 pcs.

Raised Floor (H)	Number of Anchors	Set Weight (kg)	Part No
300	4	30	CPA-X-7012
600	4	45	CPA-X-7013

## STABILIZER FOR CEILING



Material	1,5 mm Steel
Finish	Zinc Plated
Packaging	Set includes 4 pieces vertical profiles and 2 pieces ceiling fixing profiles, bolts

Cabinet D (mm)	H (mm)	Part No
300 (ETSI)	1000	CPA-0-7005
600	1000	CPA-0-7006
800	1000	CPA-0-7007
1000	1000	CPA-0-7008
1200	1000	CPA-0-7009

X (Color code): 7:RAL 7035 Light Grey, 9:RAL 9005 Black

# SPECIAL CABLE CHANNEL SYSTEMS

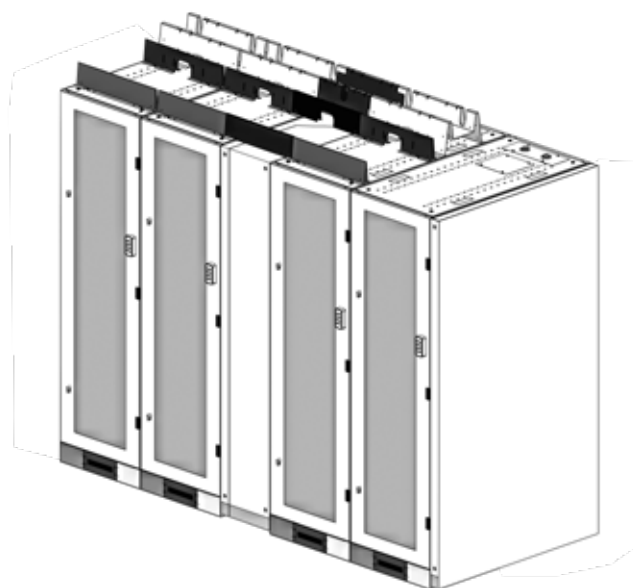

## Overview

Canovate® recommends to use special cable channel systems on top of the cabinets, when you don't have any raised floor or cable tray systems in your Data Centers.

This system is a very cost effective solution especially for Data Centers with cold aisle containment systems and inrow front coolers, where you don't need a raised floor.

These channel systems help to guide, route and manage any copper or fiber cable directly through the top cover inside the rack.

## DATA CABLE GATE SHIELD

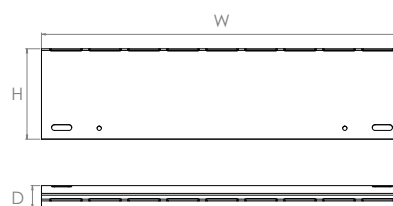

Material	1,5 mm Steel
Finish	Electrostatic Powder Paint
Color	Ral 7035 or 9005
Packaging	One piece in a box

W (mm)	D (mm)	H (mm)	Weight (kg)	Part No
500	75	125	1,50	CCA-X-6008

## DATA CABLE GATE SHIELD WITH DOUBLE SIDE ENTRY

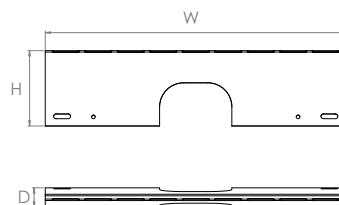

Material	1,5 mm Steel
Finish	Electrostatic Powder Paint
Color	Ral 7035 or 9005
Packaging	One piece in a box

W (mm)	D (mm)	H (mm)	Weight (kg)	Part No
500	75	125	1,31	CCA-X-6009

X (Color code): 7:RAL 7035 Light Grey, 9:RAL 9005 Black

## POWER CABLE GATE

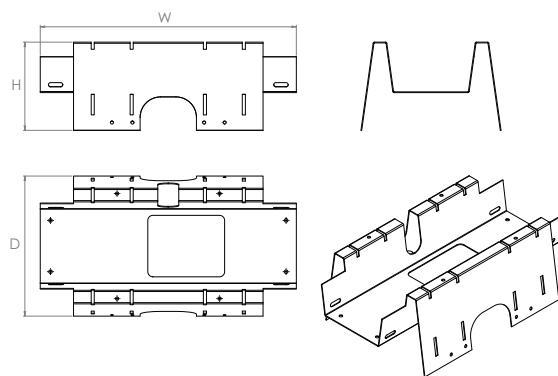
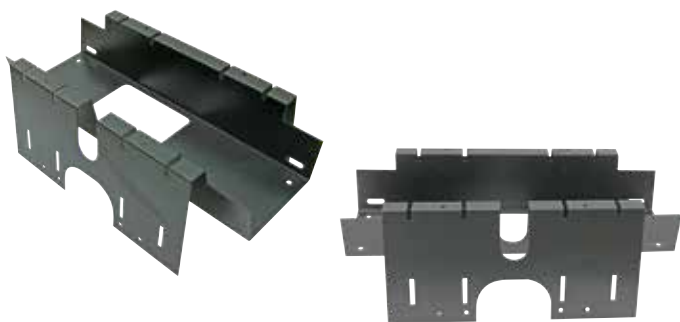

<b>Material</b>	1,5 mm Steel
<b>Finish</b>	Electrostatic Powder Paint
<b>Color</b>	Ral 7035 or 9005
<b>Packaging</b>	One piece in a box

W (mm)	D (mm)	H (mm)	Weight (kg)	Part No
500	275	175	3,15 kg	CCA-X-6001

## POWER CABLE INLET

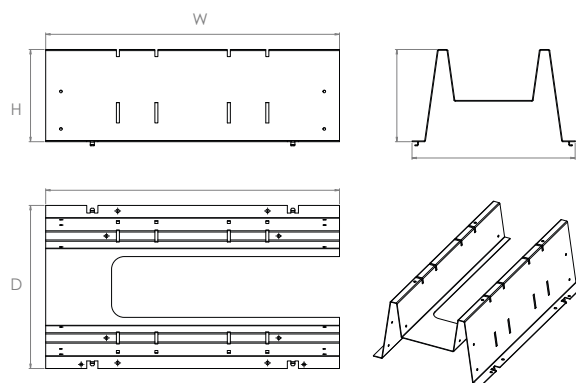

<b>Material</b>	1,5 mm Steel
<b>Finish</b>	Electrostatic Powder Paint
<b>Color</b>	Ral 7035 or 9005
<b>Packaging</b>	One piece in a box

Cabinet W (mm)	W (mm)	D (mm)	H (mm)	Weight (kg)	Part No
600	580	340	185	4,84	CCA-X-6002
800	735	340	185	6,15	CCA-X-6003

## POWER CABLE CHANNEL

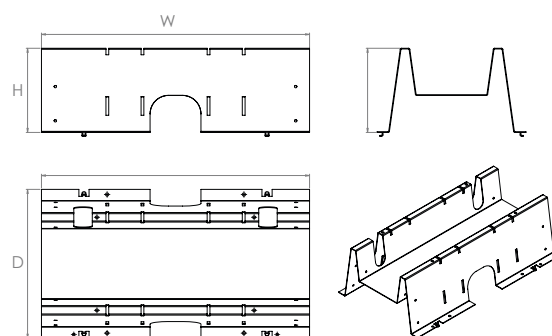

<b>Material</b>	1,5 mm Steel
<b>Finish</b>	Electrostatic Powder Paint
<b>Color</b>	Ral 7035 or 9005
<b>Packaging</b>	One piece in a box

Cabinet W (mm)	W (mm)	D (mm)	H (mm)	Weight (kg)	Part No
600	580	340	185	5,03	CCA-X-6004
800	735	340	185	6,35	CCA-X-6005

\* X : Color code = 7: RAL 7035 (Grey); 9: RAL 9005 (Black)

## DATA CABLE SHIELD WITH ONE SIDE ENTRY

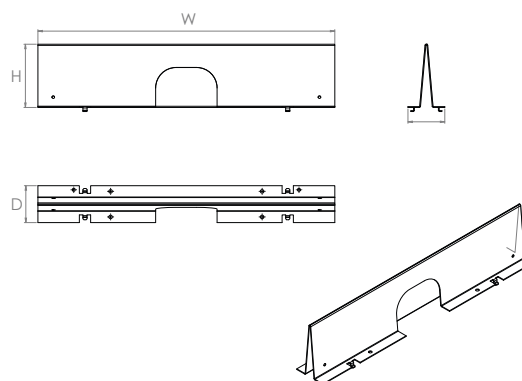

Material	1,5 mm Steel
Finish	Electrostatic Powder Paint
Color	Ral 7035 or 9005
Packaging	One piece in a box

Cabinet W (mm)	W (mm)	D (mm)	H (mm)	Weight (kg)	Part No
600	580	75	125	1,87	CCA-X-6010
800	735	75	125	2,75	CCA-X-6011

## DATA CABLE SHIELD WITH DOUBLE SIDE ENTRY

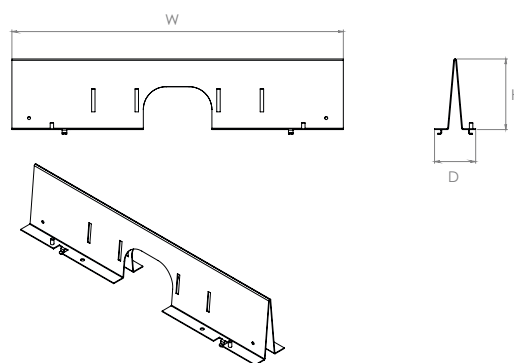

Material	1,5 mm Steel
Finish	Electrostatic Powder Paint
Color	Ral 7035 or 9005
Packaging	One piece in a box

Cabinet W (mm)	W (mm)	D (mm)	H (mm)	Weight (kg)	Part No
600	580	100	125	1,82	CCA-X-6006
800	735	100	125	2,31	CCA-X-6007

## TELESCOPIC RAIL CABLE ORGANIZER



Material	2 mm Steel
Finish	Electrostatic Powder Paint
Color	Ral 7035 or 9005
Packaging	Two pieces in a box
Maximum Static Load	Up to 70 kg.

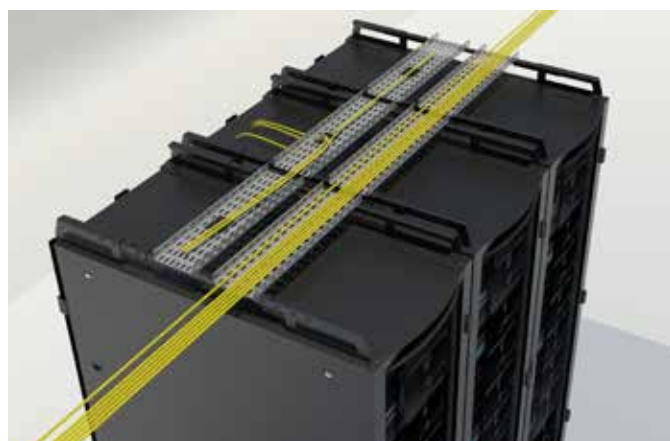

W (mm)	D (mm)	H (mm)	Weight (kg)	Part No
75	548-1148	150	4	CCA-X-7035

\* X : Color code = 7: RAL 7035 (Grey); 9: RAL 9005 (Black)